

# STOCKPICKER WORK PLATFORM - SP-175-84B

APPROX WEIGHT: 237.20 lbs.  
 DOES NOT INCLUDE WEIGHT OF POWER OR PACKAGING!!!

\*\*\*ANY ADDITIONS, DELETIONS, OR OMISSIONS MUST BE CORRECTED ON THIS DRAWING AS THIS DRAWING WILL BE CONSIDERED ALL INCLUSIVE\*\*\*  
 DIMENSION TOLERANCE ± 1/4"

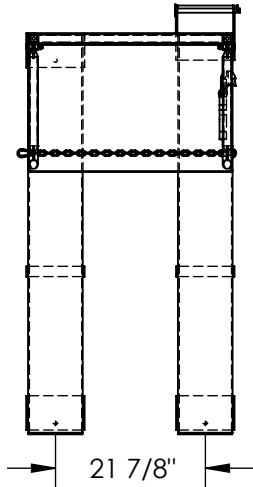

YELLOW UPPER BACK  
 (REMAINDER OF UNIT IS BLUE)

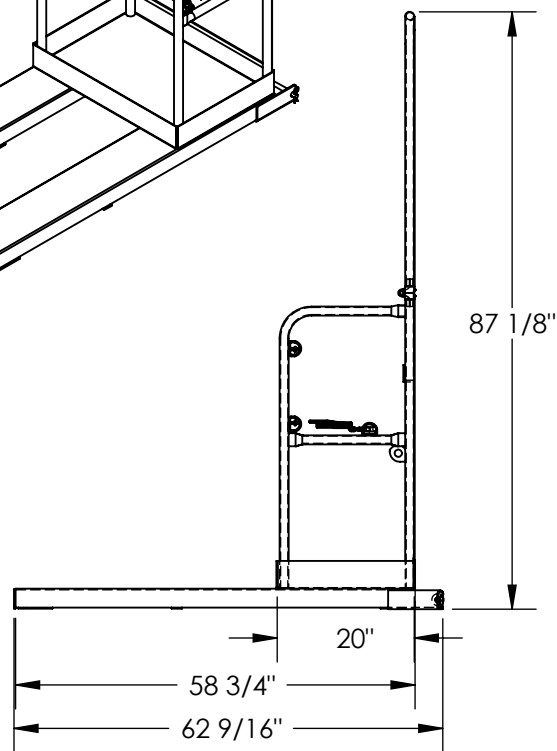
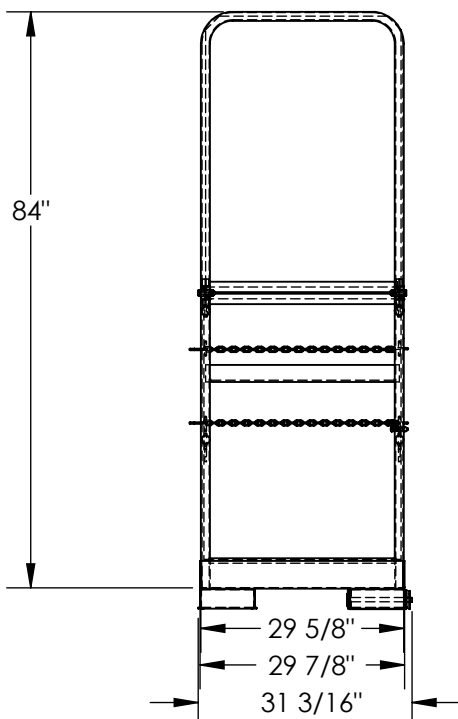
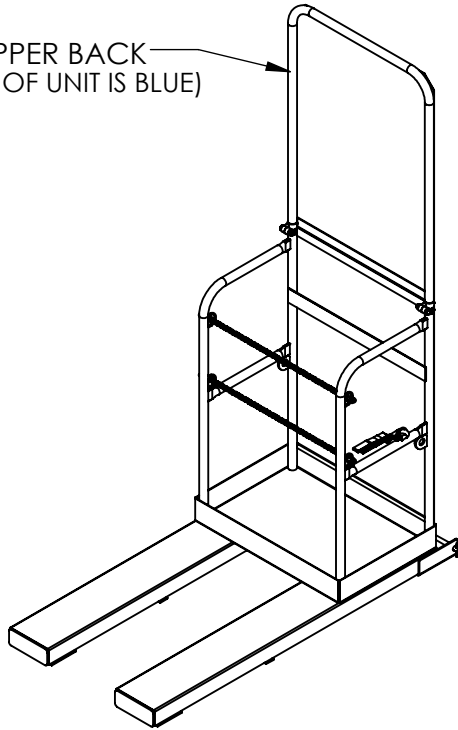

## STANDARD FEATURES

- MODEL NUMBER IS SP-175-84B
- OVERALL WIDTH IS 31 3/16"
- USABLE WIDTH IS 29 7/8"
- OVERALL LENGTH IS 62 9/16"
- USABLE LENGTH IS 58 1/4"
- OVERALL HEIGHT IS 87 1/8"
- PLATFORM SIZE IS 29 5/8" X 20"
- FORK POCKET CENTER IS 21 7/8"
- EXPANDED METAL BACK HEIGHT IS 84"
- TOUGH BAKED IN POWDER COATED ERGO BLUE FINISH FRAME AND YELLOW UPPER BACK
- MAX CAPACITY IS 4000 LBS.
- 1,000 LBS BASKET CAPACITY
- 3,000 LBS PLATFORM CAPACITY
- LOST LOAD IS 237.20 LBS. (APPROX)
- EFFECTIVE THICKNESS IS FORK LENGTH MINUS 58 3/4"

ALL GRAPHICS PROVIDED ARE FOR REFERENCE ONLY. IF CERTAIN DIMENSIONS ARE CRITICAL PLEASE VERIFY THOSE DIMENSIONS WITH YOUR SALESPERSON

NEVER EXCEED LOAD CENTER RATING PER FORK TRUCK MANUFACTURER'S GUIDELINES.  
 DO NOT USE THIS FORK TRUCK ATTACHMENT IF LOAD WILL EXCEED FORK TRUCK MANUFACTURER'S LOAD CENTER RATING.

## SPECIAL FEATURES

NONE

APPROVAL

I, THE UNDERSIGNED, AGREE THAT THE PRODUCT AS REPRESENTED SATISFIES DESIGN AND DIMENSION REQUIREMENTS. I ALSO ACKNOWLEDGE MY DUTY TO CONFIRM PRODUCT AND INSTALLATION COMPLIANCE WITH ALL APPLICABLE FEDERAL, STATE AND LOCAL REGULATIONS AND STANDARDS.  
**UNITS REQUIRING APPROVAL DRAWINGS OR MODIFIED ARE NON-RETURNABLE**  
 As drawn       As marked

Signed: \_\_\_\_\_ Date: \_\_\_\_\_

Printed Name: \_\_\_\_\_

LEAD TIME WILL START UPON RECEIPT OF SIGNED APPROVAL DRAWING

DISTRIBUTOR'S NAME:		P.O.#
VESTIL MANUFACTURING		X
		W.O.#
DRAWN BY: DEY		X
DATE: 7/9/2010		SALES: X
REFERENCE: X	SCALE: 1:28	FILE NAME:
QUOTED LEAD TIME: X	QUOTE # X	14-007-085